



CORONA

Discovering the view from space

CORONA

The CORONA program was the first US imaging intelligence (IMINT) satellite program operating from 1960 to 1972. The covert mission and CORONA program name were concealed from public disclosure. Publicly it was called WS-117L/“Discoverer Program” conducting experiments in space. The IMINT mission was not publicly revealed until 1995.

The first successful space flight in 1960 took place soon after a SA-2 missile shot down our U-2 reconnaissance aircraft on a mission over the USSR.

There were six CORONA design configurations (KH-1 to KH-4B)

CORONA was the technical forerunner of GAMBIT & HEXAGON programs establishing the operational concepts and resolving engineering design issues that arose in the heretofore unfamiliar space environment.

The operational value of its images during these early stages of the cold war made it an important strategic asset as well as defining critical technology for future programs.

CORONA IN THE COLD WAR

EVENTS (COLD WAR = 1947 – 1991)

- 1957 - FIRST USSR ATOMIC BOMB
- 1960 - FIRST USSR OPERATIONAL ICBM
- 1960 - U-2 SHOT DOWN OVER USSR
- 1960 - 1980 MASSIVE COLD WAR ARMS BUILD UP
- 1972 - STRATEGIC ARMS LIMITATION TREATY (SALT-1)
- 1979 - STRATEGIC ARMS LIMITATION TREATY (SALT-2)
- 1982 - STRATEGIC ARMS REDUCTION TALKS (START)
- 1991 - COLD WAR END

CORONA EVENTS

- 1960 – FIRST CORONA LAUNCH
 - JUST 3 YEARS AFTER THE FIRST US SATELLITE
 - REPLACED AIRCRAFT FLIGHTS OVER DENIED COUNTRIES
- 1972 – LAST CORONA MISSION OPERATED AREA COVERAGE BEFORE HEXAGON
 - SIX DESIGN CONFIGURATION
 - 122 SATELLITES BUILT

U-2 SHOT DOWN OVER USSR



CORONA HISTORIC ACCOMPLISHMENTS

EWO Capability Increase -
1350 - 4895 lbs

Payload Increase -
375 - 1850 lbs

Active Life Increase -
1 - 20 days

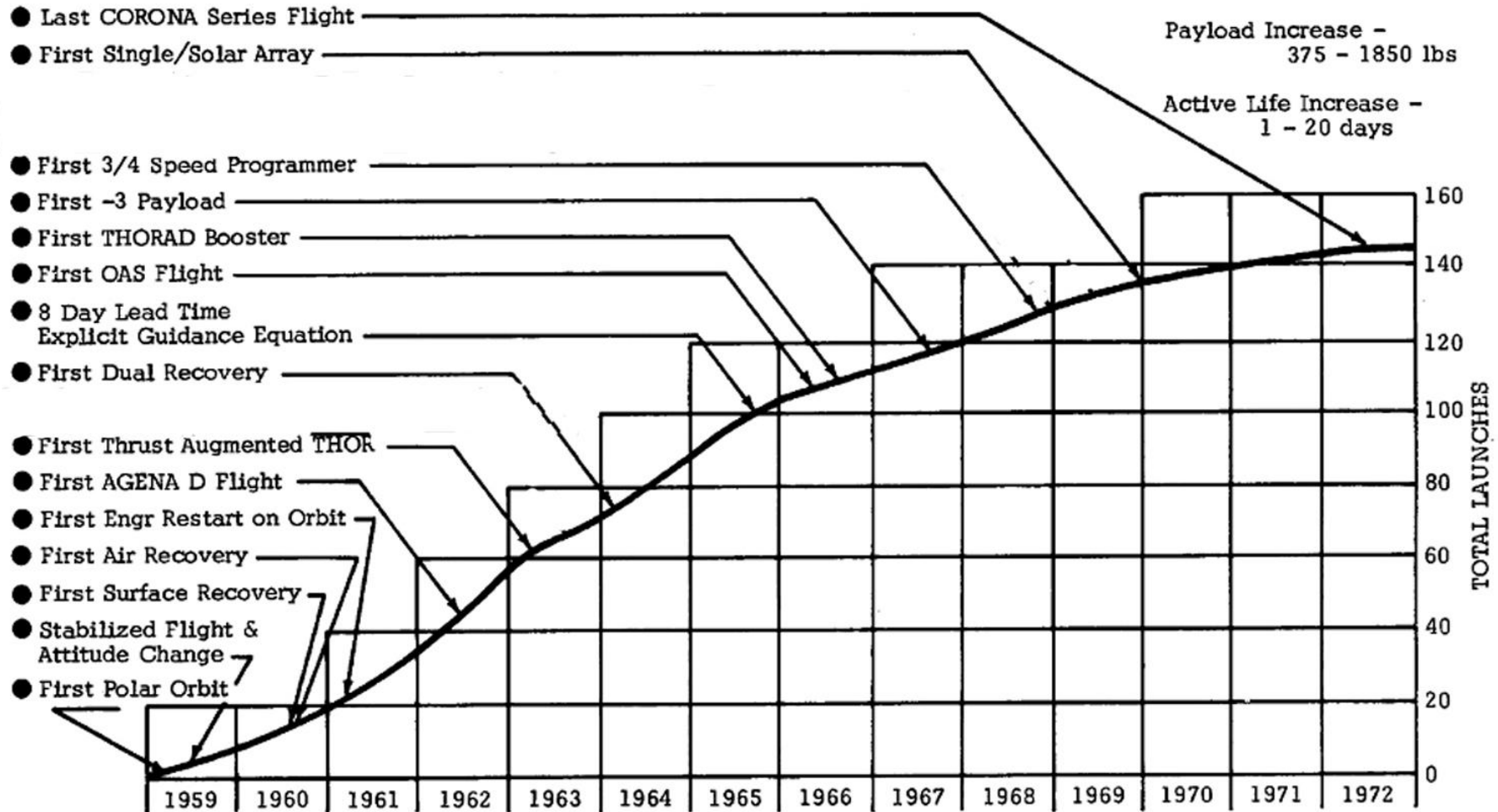

Launches	8	11	17	22	17	15	14	9	9	8	6	4	3	2
Recoveries	0	4	7	16	12	23	25	16	18	16	12	8	4	4

CORONA /AGENA INTEGRATED DESIGN

The CORONA camera payload was mated to an Agena booster upper stage for launch to orbit and remained attached to provide bus support functions like power, attitude control, orbit adjust, telemetry, and command interface to the camera mission payload.

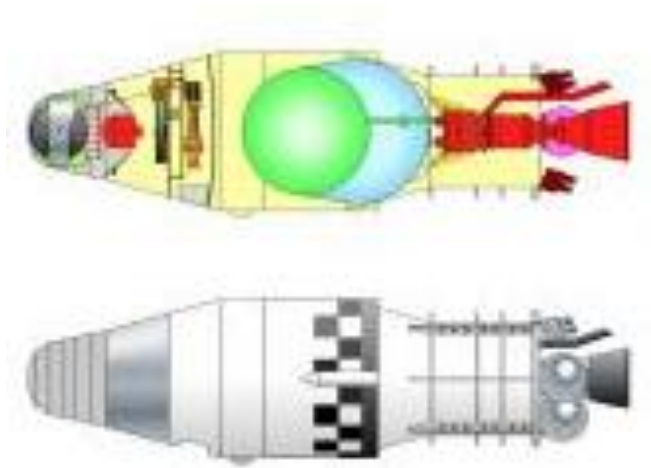

CORONA 1 VEHICLE



CORONA 4 VEHICLE

CORONA VEHICLE DESIGN PROGRESSION

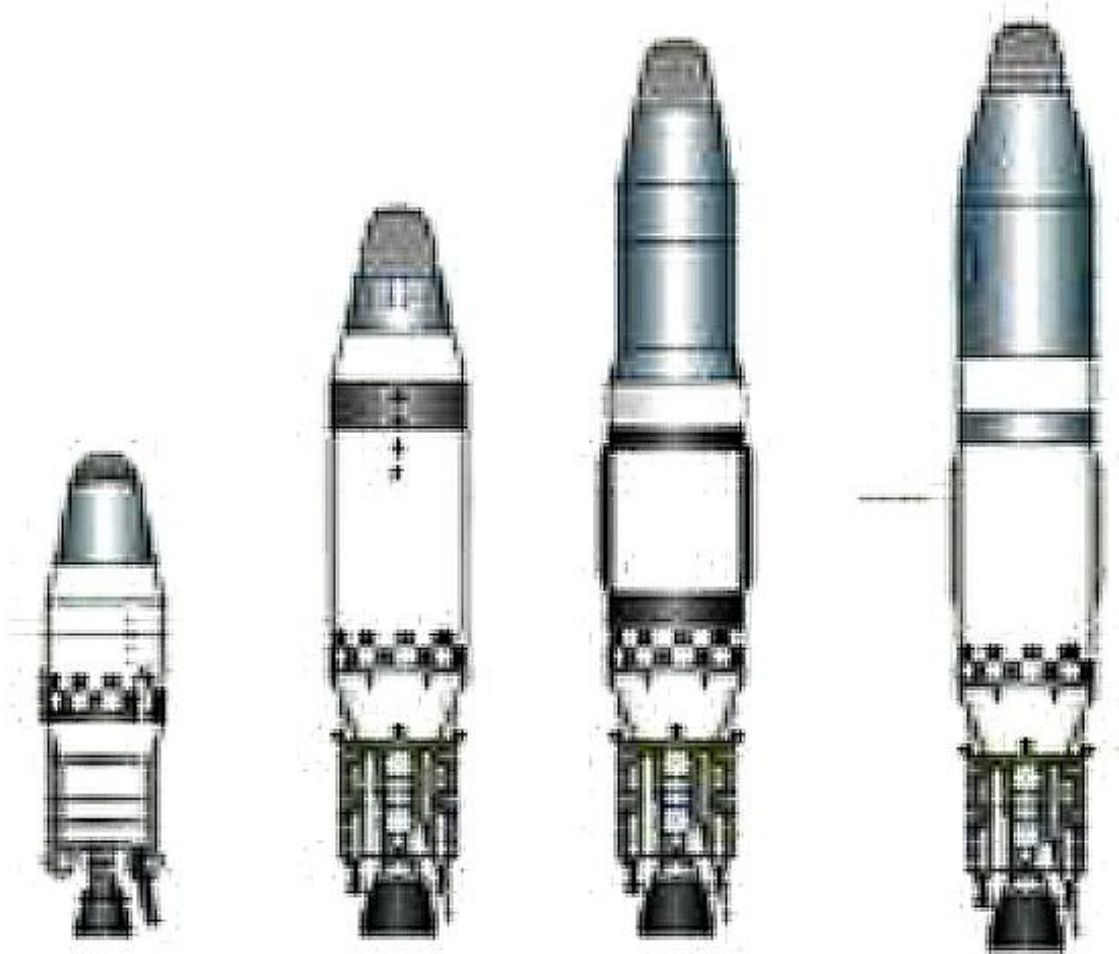

**KH-1/2/3
DISCOVERER**

**KH-4
CORONA**

**KH-4A
CORONA**

**KH-4B
CORONA**

CORONA BLOCK DESIGNATION AND DESIGN EVOLUTION

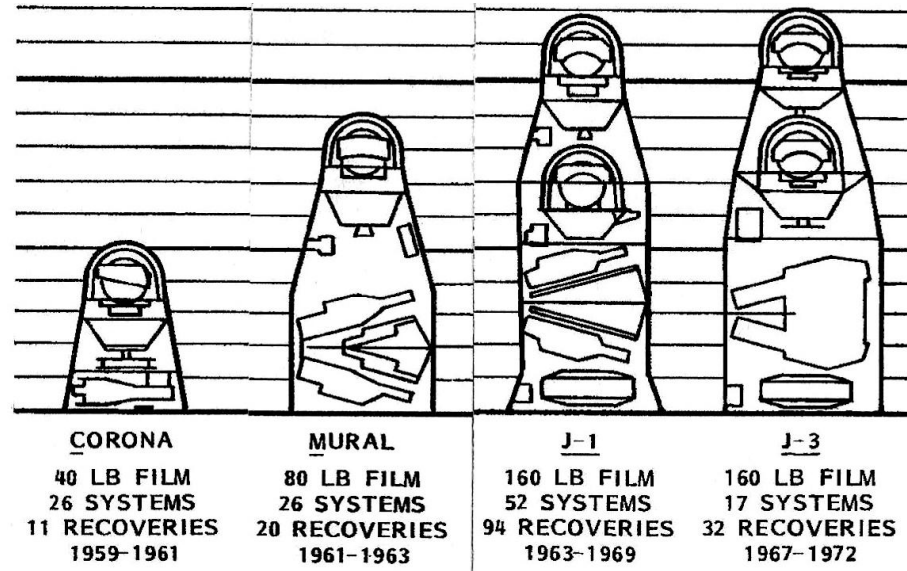

Camera Designation	KH #	Camera Type	Focal Length (in)	/f	Film-type	Thickness (mil)	Film Width (in)	Film Weight (lbs)	Mapping Camera	/f	Type	Film Type	Thickness (mil)
C	KH-1	Tessar 70° pan verticle reciprocating	24	5.0	1213/acetate	5.25		40					
C'	KH-2	Tessar 70° pan verticle reciprocating	24	5.0	1221/polyester	2.75		40					
C'''	KH-3	Petzval 70° pan verticle reciprocating	24	3.5	4404/polyester	2.5	1.5	40	Stellar Index (SI)	4.5	Biogon	3400 polyester	2.5
MURAL	KH-4	Petzval 70° pan 30° stereo reciprocating	24	3.5	4404/polyester	2.5	1.5	80	Stellar Index (SI)	4.5	Biogon	3400 polyester	2.5
JANUS-J1	KH-4A	Petzval 70° pan 30° stereo reciprocating	24	3.5	3404/polyester	2.5	1.5	160	Stellar Index (SI)	4.5	Biogon	3400 polyester	2.5
JANUS-J3-CR	KH-4B	Petzval 70° pan 30° stereo rotating	66	5.0	3404/3414 polyester	2.5	3.0	160	DISIC	4.5	Ikogon	3400 polyester	2.5

KH-1 CAMERA (TYPE C)

CORONA HISTORY
Volume III

THE FIRST SATELLITE CAMERA CONFIGURATION - C MODEL

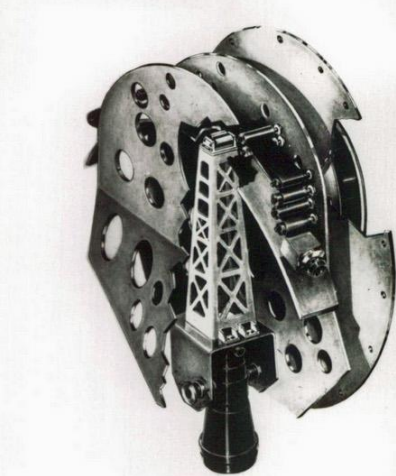

Artist's View of Camera



Itek's f/5.0, 24 Inch Lens

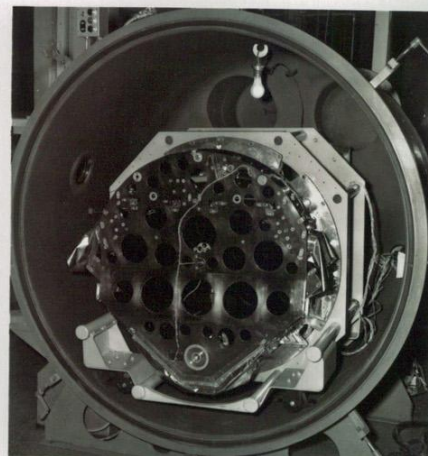

Camera in Vacuum Chamber



Rear View (film spool side) of Camera

CORONA C''' (TRIPLE PRIME) CAMERA



Front View

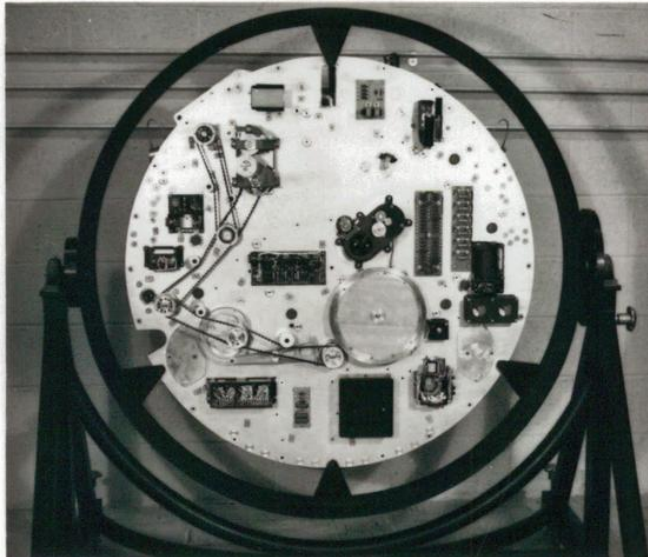

CORONA J3-CAMERA

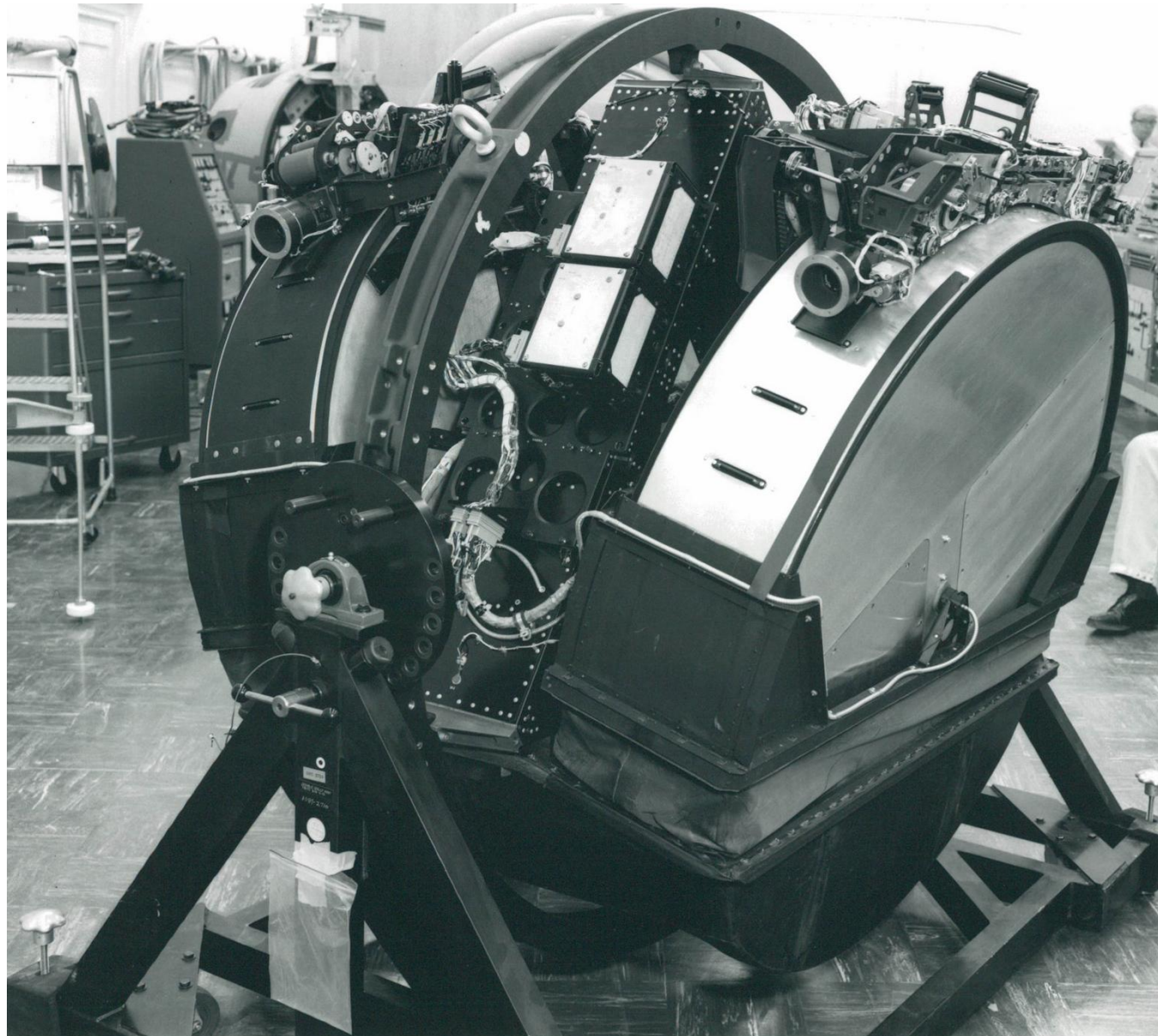

CORONA KH-4A & KH-4B CAMERA SYSTEM DESIGN

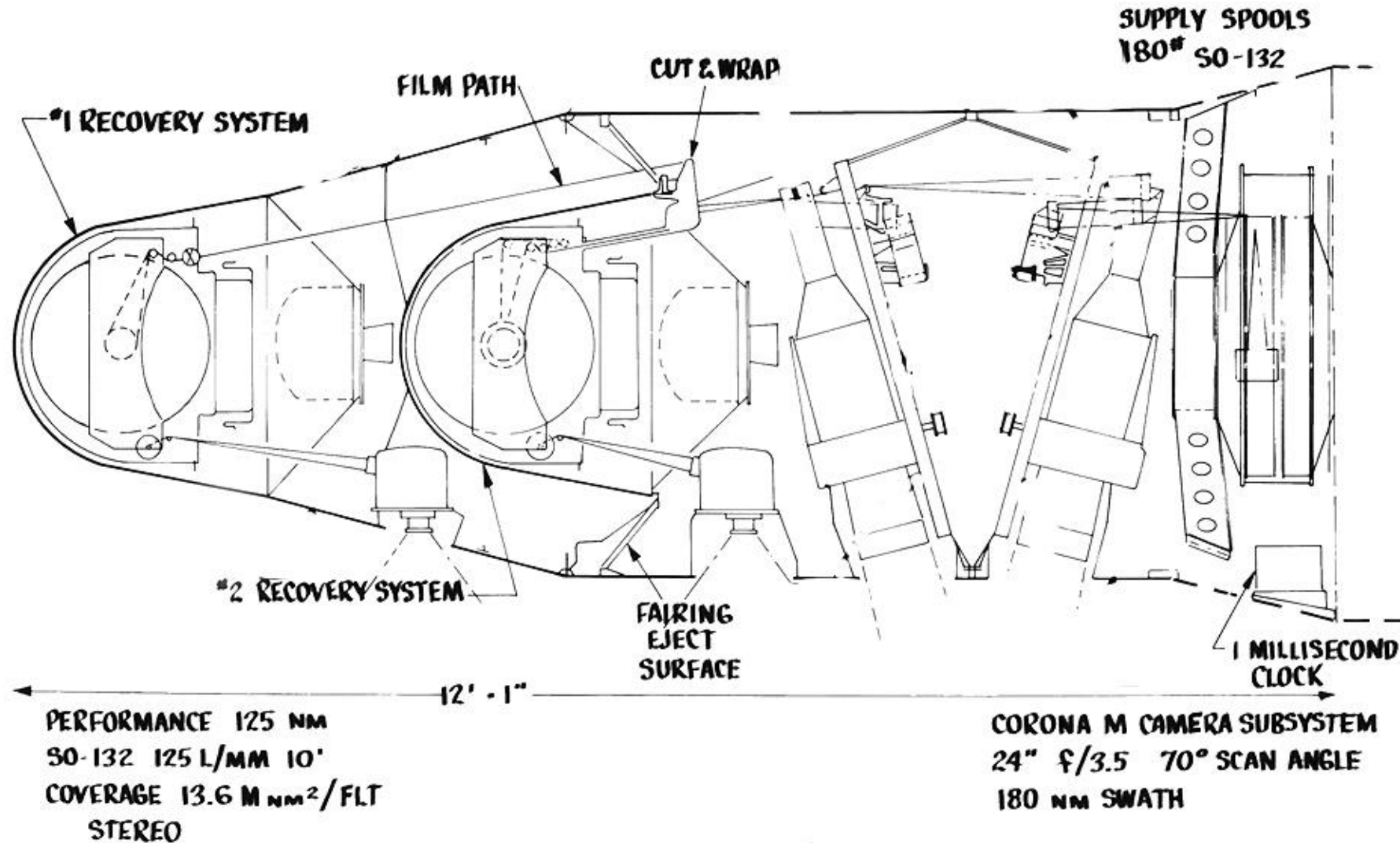

CORONA KH-4B STELLAR (DISIC) CAMERA

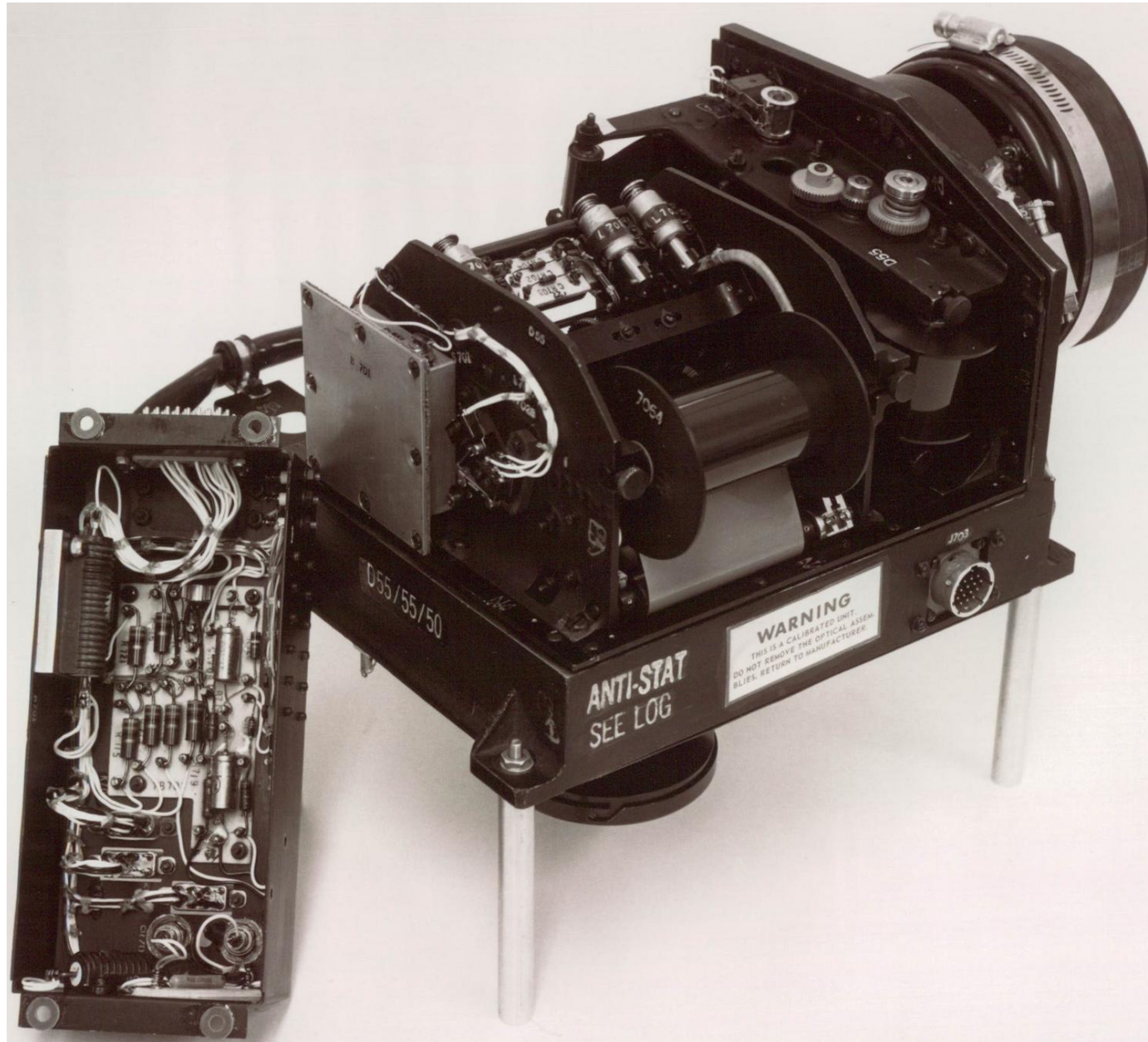

CORONA KH-4A&B ASSEMBLY & TEST FLOW

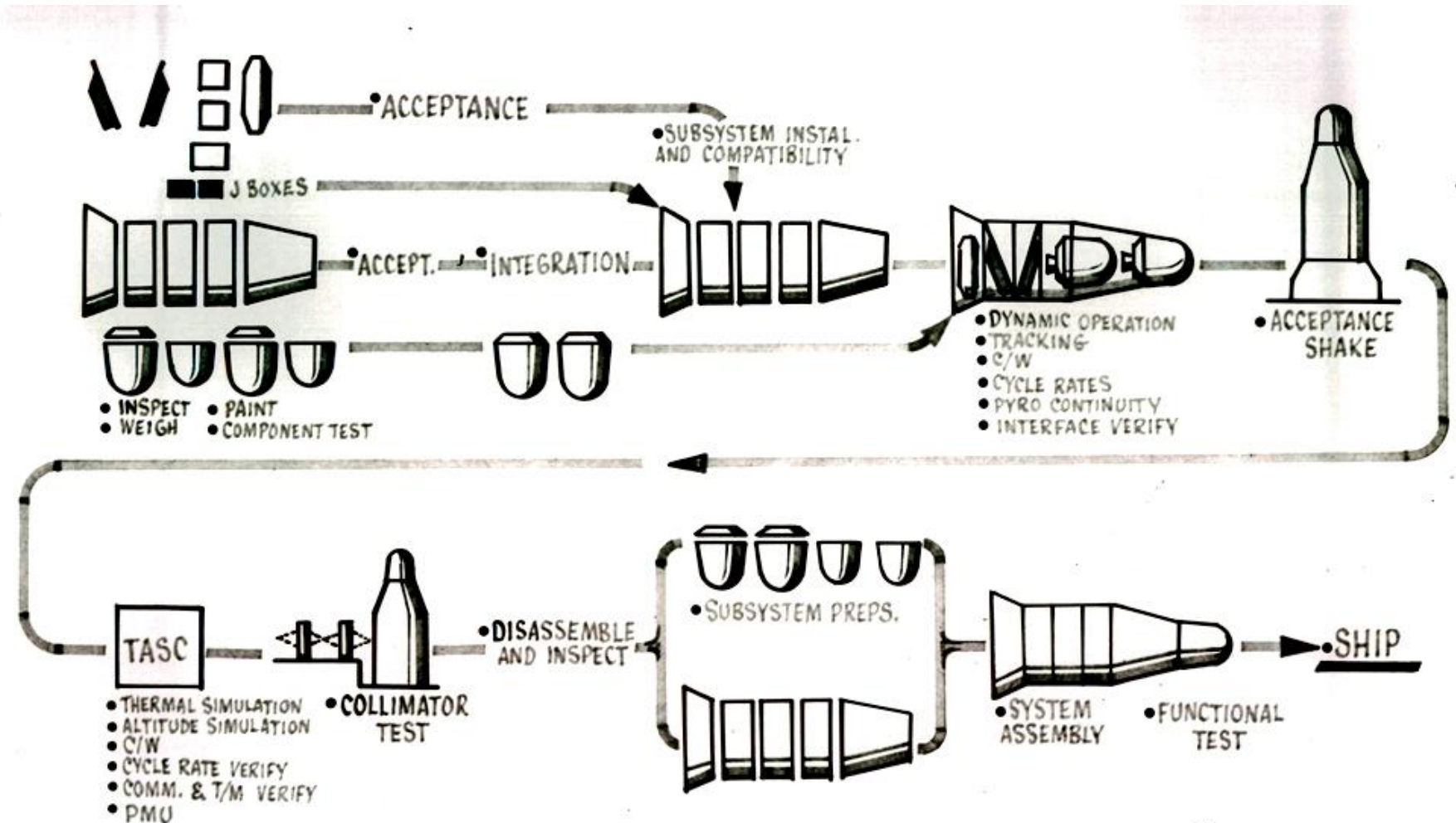
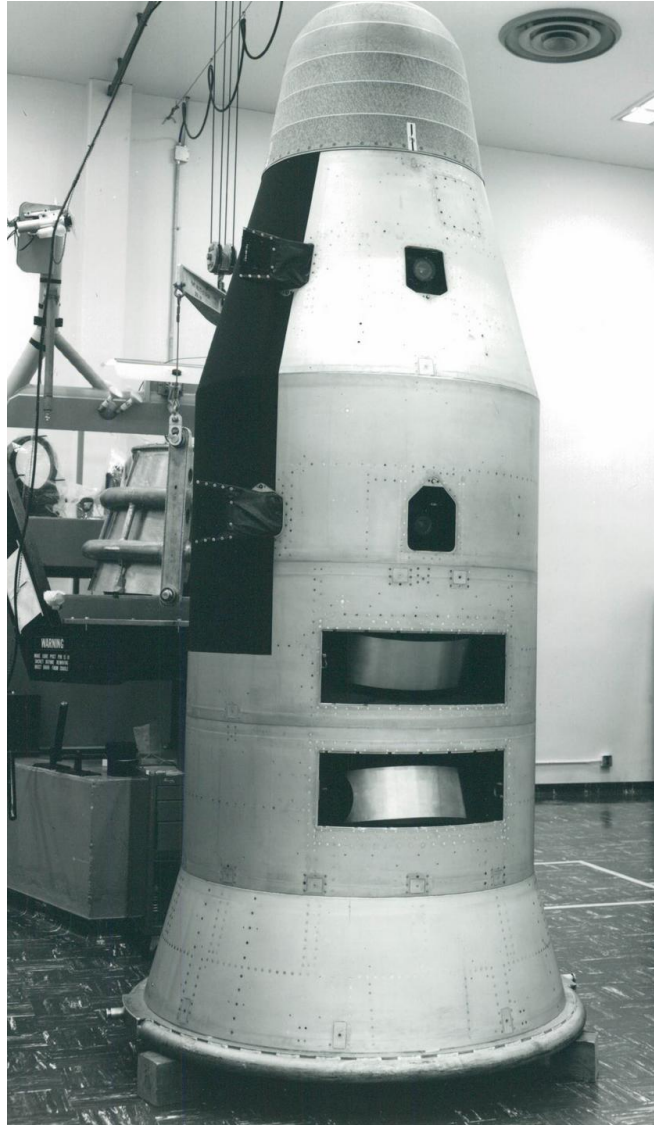

THERMAL VACUUM TESTING

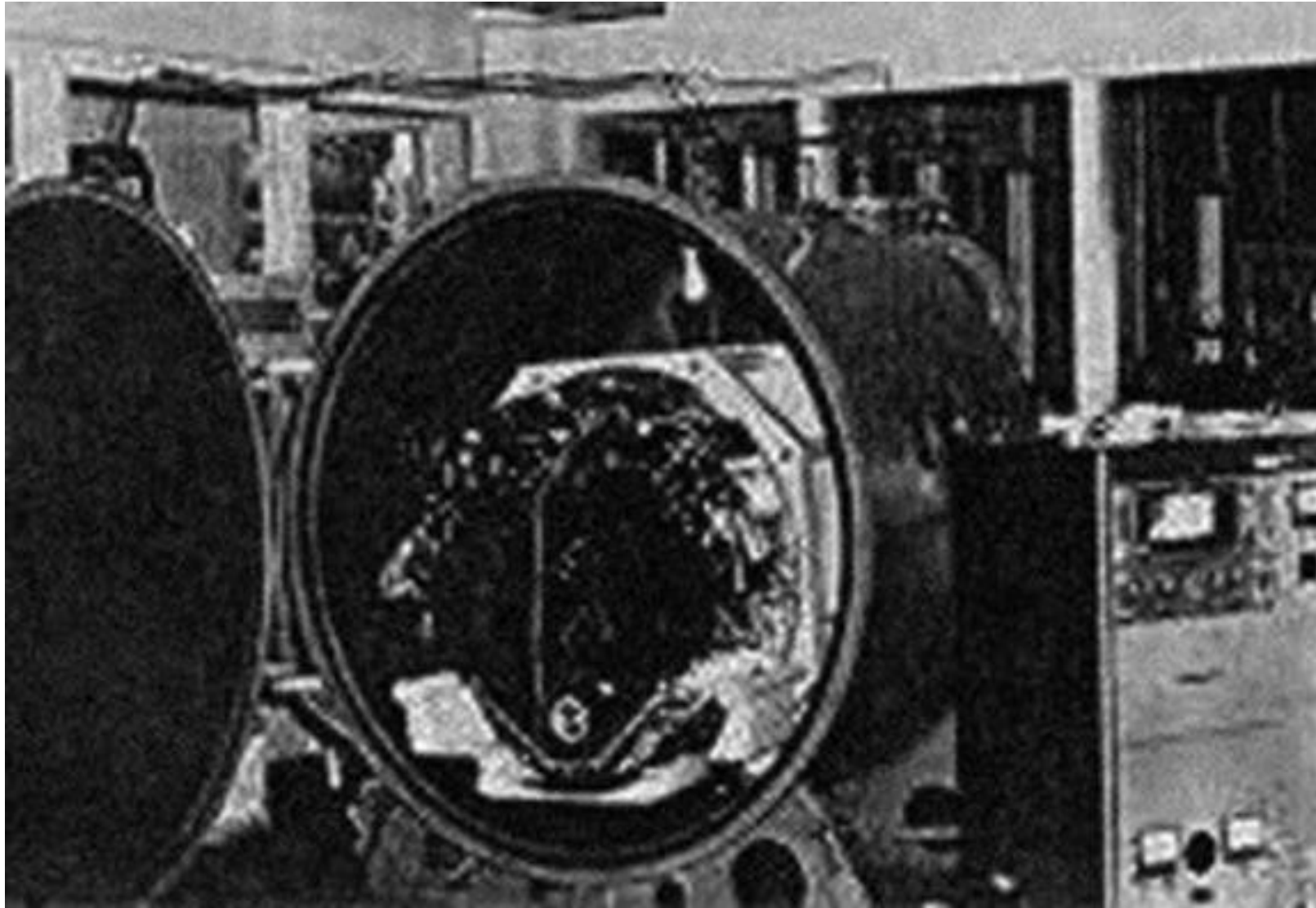

CORONA ATLAS-AGENA LAUNCH



CORONA J IMAGING OPERATION

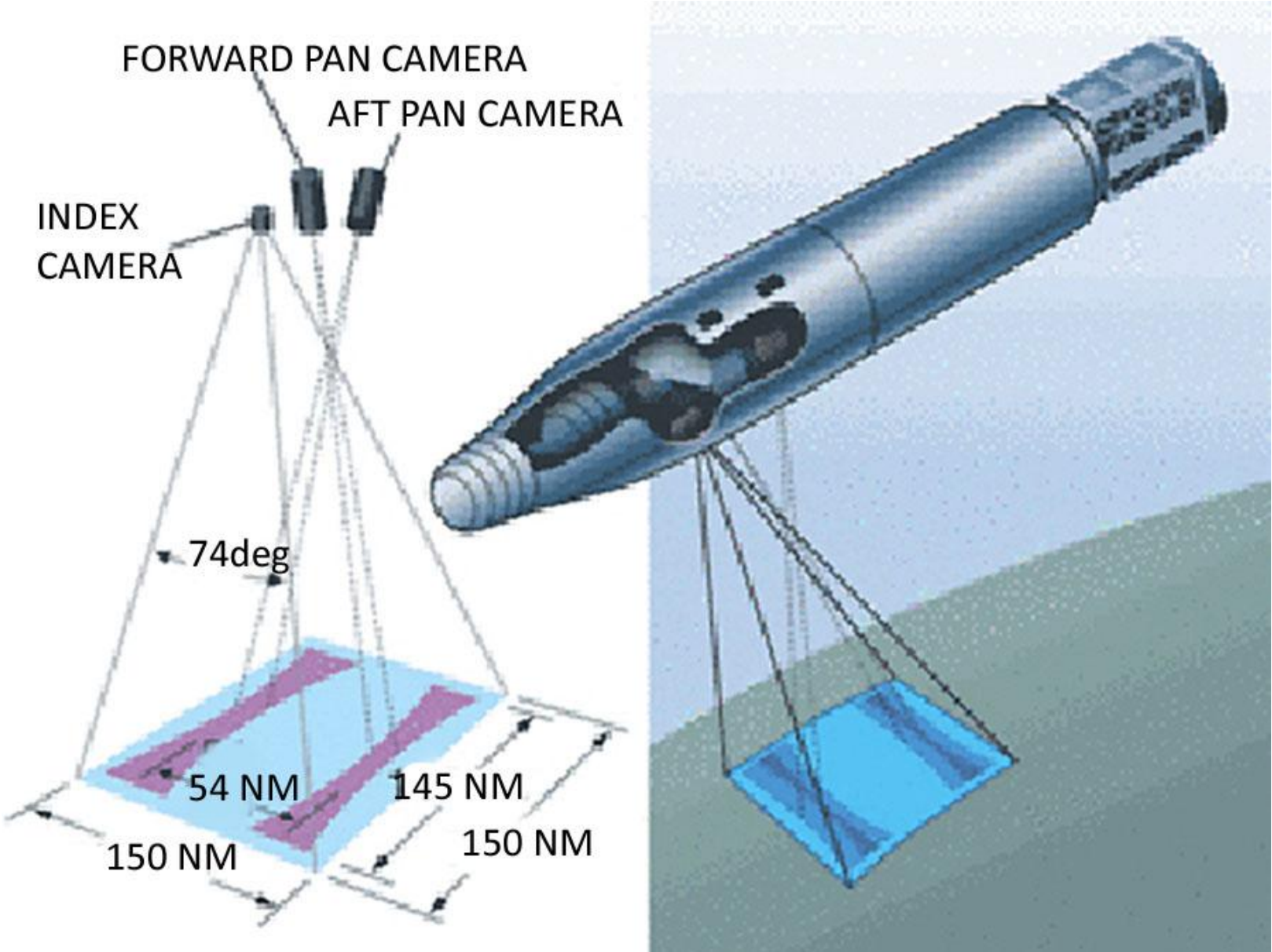

CORONA RECOVERY SEQUENCE

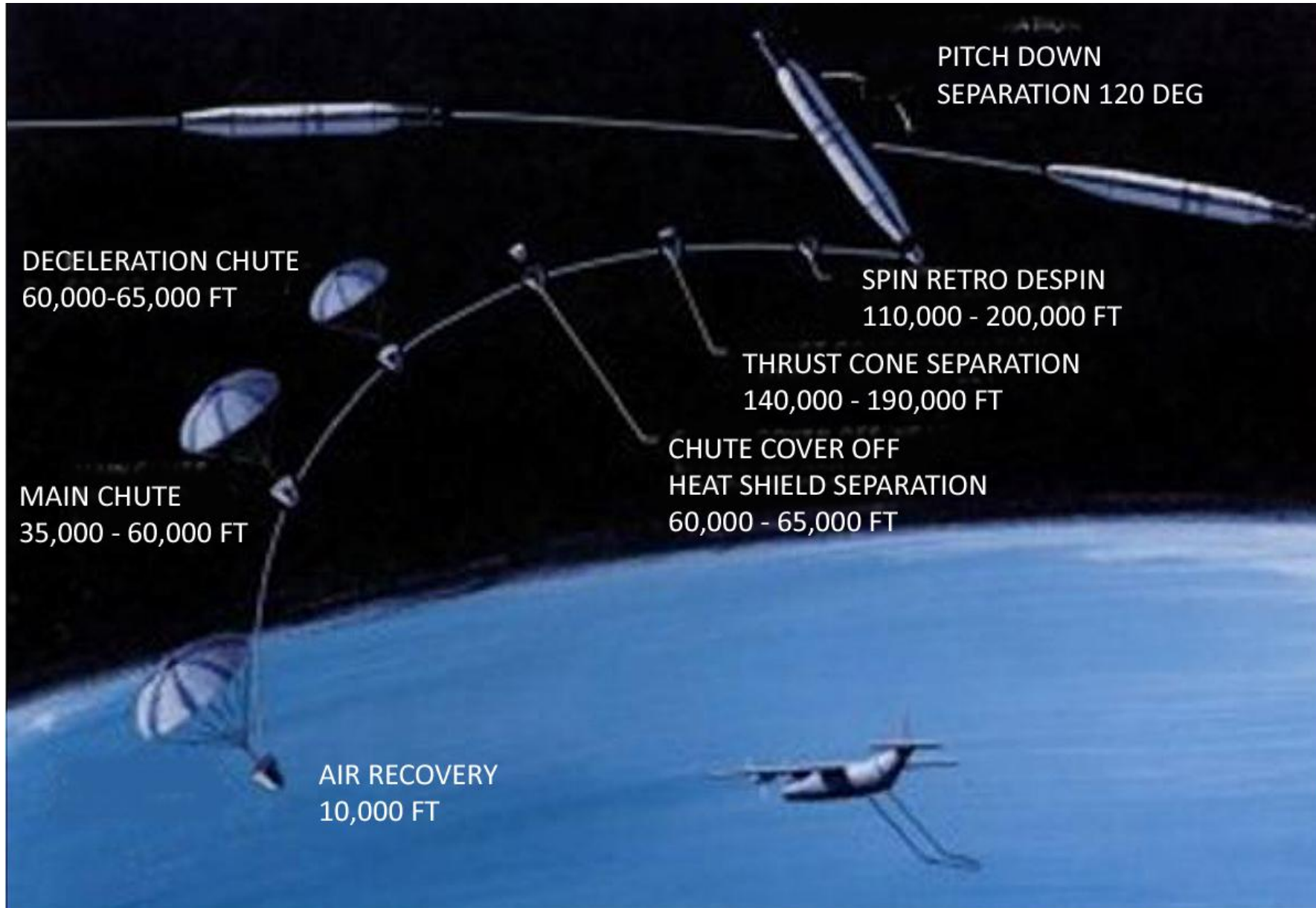

CORONA RECOVERY COORDINATION

RE-ENTRY PARAMETERS

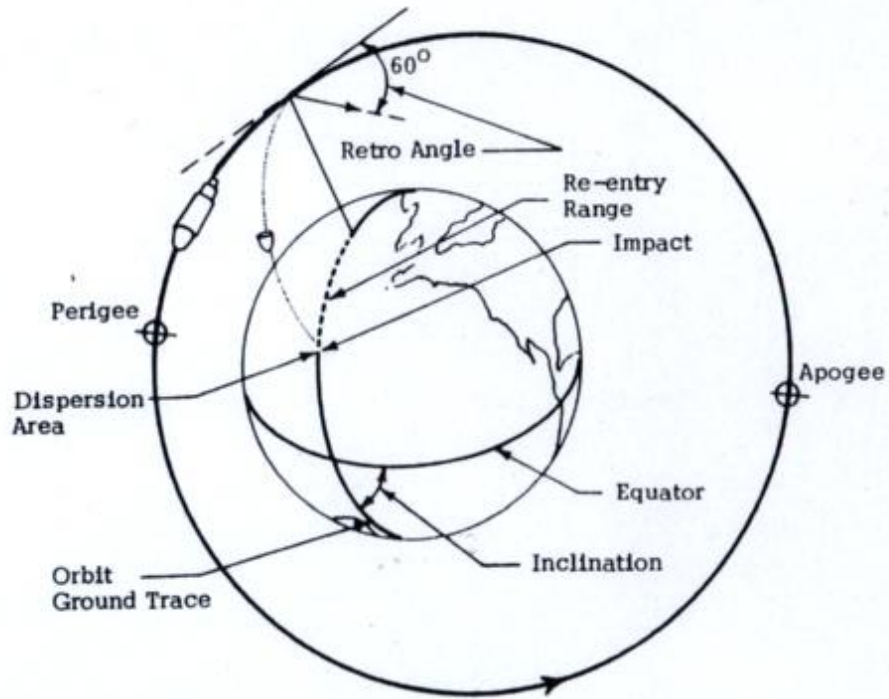

MISSION

- Perigee - 85 nm
- Apogee - 210 nm
- Period - 90,04 min

RE-ENTRY PERFORMANCE

- Retro Velocity - 850 fps
- Retro Angle - 60°
- $\frac{W}{CDA} - 68 \frac{\text{lbs}}{\text{ft}^2}$
- Range - 1,900 nm
- Dispersions (normal)

Up range	50 - 100 nm
Down range	60 - 180 nm
Cross range	± 10 nm

- Heating

$$q \text{ Total } 27,000 \text{ btu/ft}^2 \text{ (limit)}$$

SATELLITE CONTROL FACILITY OPERATION IN RECOVERY

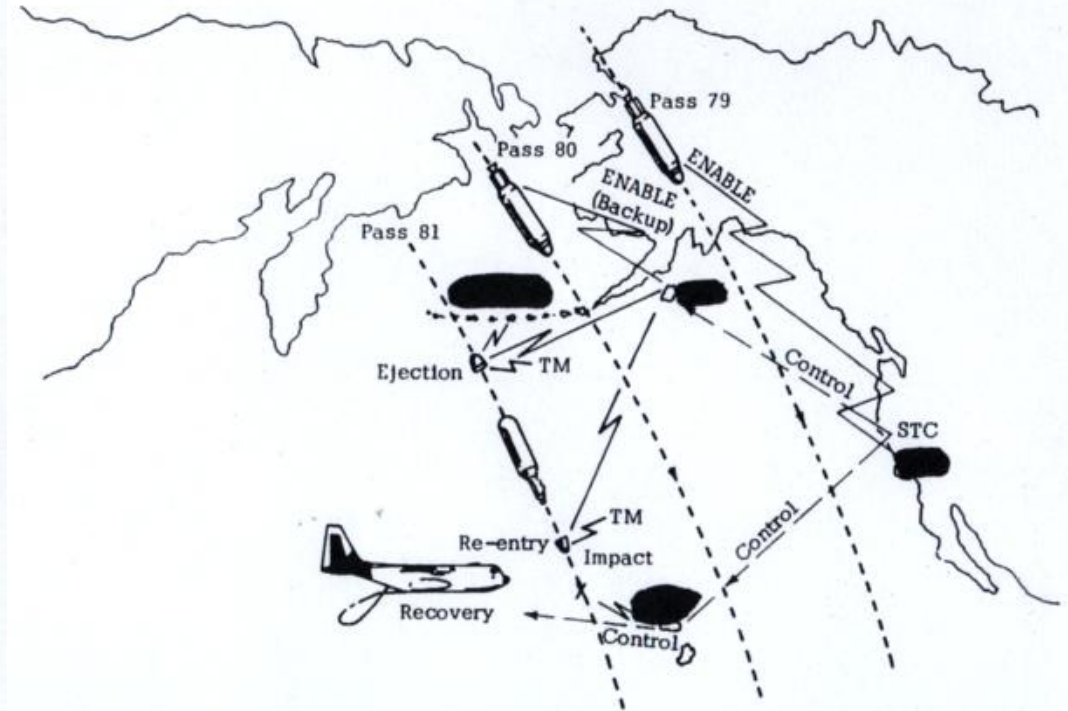

AERIAL RECOVERY

(C-119 AIRCRAFT WAS REPLACED BY JC-130)

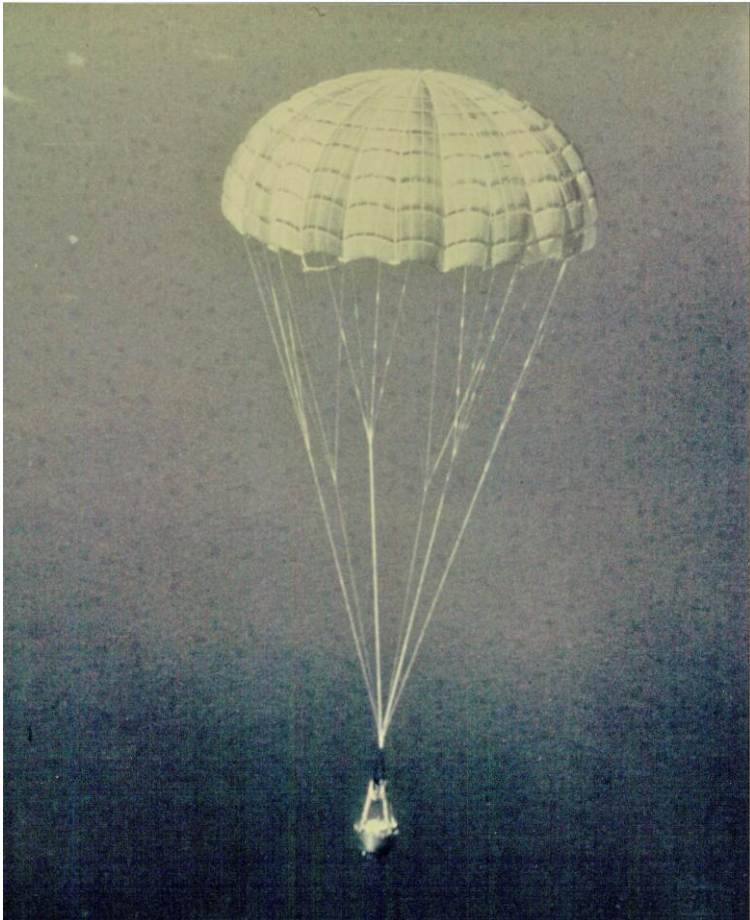

C-119 RECOVERY AIRCRAFT

(NOW ON DISPLAY AT AIR FORCE MUSEUM)



CORONA FILM RECOVERY VEHICLE



PRESIDENT EISENHOWER “D-XIII Discovery” RECOVERED CAPSULE



CORONA MISSION PERFORMANCE

(PAGE 1 OF 2)

LAUNCH DATE	DESIGN TYPE	COMMENTS	LAUNCH DATE	DESIGN TYPE	COMMENTS
18-Aug-60	KH-1	First successful recovery of IMINT from space	21-Dec-63	KH-4	Corona static fogged much of film.
7-Dec-60	KH-2	First successful mission employing KH-2 camera system.	24-Aug-63	KH-4A	First mission of KH-4A. Some film was fogged. Two buckets but 1001-2 was never recovered.
12-Sep-61	KH-3	Best mission to date. Same out-of-focus condition	23-Sep-63	KH-4A	Severe light leaks
13-Oct-61	KH-3	Capsule recovered on orbit 18. 96% of film out of focus.	15-Feb-64	KH-4A	Main cameras operated satisfactorily. Minor degradations due to static and light leaks.
15-Nov-61	KH-3	All cameras operated satisfactorily. Grainy emulsion noted.	4-Jun-64	KH-4A	Highest quality imagery attained to date from the KH-4 system.
12-Dec-61	KH-3	Best mission to date. Launch carried OSCAR 1 to orbit.	10-Jun-64	KH-4A	Cameras operated satisfactorily
27-Feb-62	KH-4	First mission of the KH-4 series. Much of film slightly out of focus.	19-Jun-64	KH-4A	Out-of-focus area on some film.
18-Apr-62	KH-4	Best mission to date.	5-Aug-64	KH-4A	Cameras operated successfully.
30-May-62	KH-4	Slight corona static on film.	14-Sep-64	KH-4A	Small out of focus areas on both cameras at random times throughout the mission.
23-Jun-62	KH-4	Corona static occurs on some film.	5-Oct-64	KH-4A	Primary mode of recovery failed on second portion of the mission (1011-2). Small out of focus areas present at random on both cameras.
28-Jun-62	KH-4	Severe corona static.	17-Oct-64	KH-4A	Vehicle attitude became erratic on the second portion of the mission necessitating an early recovery.
21-Jul-62	KH-4	Aborted after 6 photo passes. Heavy corona and radiation fog.	2-Nov-64	KH-4A	Program anomaly occurred immediately after launch when both cameras operated for 417 frames. Main cameras ceased operation on rev 52D of first portion of mission negating second portion. About 65% of aft camera film is out of focus.
28-Jul-62	KH-4	No filters on slave horizon cameras. Heavy corona and radiation fog.	18-Nov-64	KH-4A	Cameras operated successfully.
2-Aug-62	KH-4	Severe corona and radiation fog.	18-Nov-64	KH-4A	Cameras operated successfully.
29-Aug-62	KH-4	Erratic vehicle attitude. Radiation fog minimal.	19-Dec-64	KH-4A	Discrepancies in planned and actual coverage due to telemetry problems during the first 6 revolutions. Small out-of-focus areas on film from aft camera.
17-Sep-62	KH-4	Placed in highly eccentric orbit (207 km x 670 km), capsule called down after one day, film suffered severe radiation fog due to SAA crossing	15-Jan-65	KH-4A	Smearing of highly reflective images due to reflections within camera.
29-Sep-62	KH-4	First use of stellar camera	25-Feb-65	KH-4A	Capping shutter malfunction occurred during last 5 passes of mission.
24-Nov-62	KH-4	Some film exposed through base.	25-Mar-65	KH-4A	Cameras operated successfully. First KH-4A reconnaissance system to be launched into a retrograde orbit.
14-Dec-62	KH-4	Best mission to date.	29-Apr-65	KH-4A	Cameras operated successfully. Malfunction in recovery mode on 1019-2 negated recovery.
7-Jan-63	KH-4	Erratic vehicle attitude. Frame ephemeris not created.	18-May-65	KH-4A	Aft camera ceased operation on pass 102.
1-Apr-63	KH-4	Best imagery to date.	9-Jun-65	KH-4A	All cameras operated satisfactorily. Erratic attitude caused an early recovery after the second day of 1020-2.
12-Jun-63	KH-4	Some imagery seriously affected by corona.	19-Jun-65	KH-4A	All cameras operated satisfactorily.
26-Jun-63	KH-4	Experimental camera carried. Film affected by light leaks.	17-Aug-65	KH-4A	Program anomaly caused the fore camera to cease operation during revolutions 103-132.
19-Jul-63	KH-4	Best mission to date.	22-Sep-65	KH-4A	All cameras operated satisfactorily. Cameras not operated on passes 88D-93D.
			5-Oct-65	KH-4A	Main cameras operated satisfactorily.

CORONA MISSION PERFORMANCE

(PAGE 2 OF 2)

LAUNCH DATE	DESIGN TYPE	COMMENTS	LAUNCH DATE	DESIGN TYPE	COMMENTS
28-Oct-65	KH-4A	All cameras operated satisfactorily.	19-Mar-69	KH-4A	Due to abnormal rotational rates after revolution 22
9-Dec-65	KH-4A	Erratic attitude necessitated recovery after two days of operation. All cameras operated satisfactorily.	2-May-69	KH-4A	Imagery of both pan camera records is soft and lacks crispness and edge sharpness.
24-Dec-65	KH-4A	Cameras operated satisfactorily.	22-Sep-69	KH-4A	Last of the KH-4A missions
2-Feb-66	KH-4A	Both panoramic cameras were operational throughout.	15-Sep-67	KH-4B	First mission of the KH-4B series. Best film to date.
9-Mar-66	KH-4A	All cameras operated satisfactorily.	9-Dec-67	KH-4B	Noticeable image smear for forward camera
7-Apr-66	KH-4A	The aft-looking camera malfunctioned after the recovery of bucket 1. No material was received in bucket 2 (1031-2).	1-May-68	KH-4B	Out-of-focus imagery is present on both main camera records.
24-May-66	KH-4A	The stellar camera shutter of bucket 2 remained open for approximately 200 frames.	7-Aug-68	KH-4B	Best imagery to date on any KH-4 systems. Bicolor and color infrared experiments were conducted on this mission, including SO-180 IR camouflage detection film.
21-Jun-66	KH-4A	Failure of velocity altitude programmer produced poor imagery after revolution 5.	3-Nov-68	KH-4B	Image quality is variable and displays areas of soft focus and image smear.
9-Aug-66	KH-4A	All cameras operated satisfactorily.	5-Feb-69	KH-4B	The best image quality to date.
20-Sep-66	KH-4A	All cameras operated satisfactorily. First mission flown with pan geometry modification.	24-Jul-69	KH-4B	Forward camera failed on pass 1 and remained inoperative throughout the rest of the mission.
8-Nov-66	KH-4A	Second pan geometry mission. Higher than normal base plus fog encountered on both main camera records.	4-Dec-69	KH-4B	Cameras operated satisfactorily and the mission carried 811 ft (247 m) of aerial color film added to the end of the film supply.
14-Jan-67	KH-4A	Fair image quality.	4-Mar-70	KH-4B	Cameras operated satisfactorily but the overall image quality of both the forward and aft records is variable.
22-Feb-67	KH-4A	Normal KH-4 mission. Light from horizon camera on both main camera records during 1039-1.	20-May-70	KH-4B	The overall image quality is less than that provided by recent missions and 2
30-Mar-67	KH-4A	Satellite flown nose first.	23-Jun-70	KH-4B	The overall image quality is good.
16-Jun-67	KH-4A	Small out-of-focus area in forward camera of 1042-1.	18-Nov-70	KH-4B	The forward camera failed on pass 104 and remained inoperative throughout the rest of the mission.
7-Aug-67	KH-4A	Forward camera film came out of the rails on pass 230D. Film degraded past this point.	24-Mar-71	KH-4B	The overall image quality is good and comparable to the best of past missions. On-board program failed after pass 235
2-Nov-67	KH-4A	All cameras operated fine.	10-Sep-71	KH-4B	Overall image quality is good.
24-Jan-68	KH-4A	All cameras operated satisfactorily.	19-Apr-72	KH-4B	Very successful mission and image quality was good.
14-Mar-68	KH-4A	Image quality good for 1046-1 and fair for 1046-2.	25-May-72	KH-4B	Last KH-4B mission. Very successful mission, failure to deploy one solar panel and leak in Agena gas system shortened mission from 19 to 6 days[63]
20-Jun-68	KH-4A	Out-of-focus imagery is present on both main camera records.			
18-Sep-68	KH-4A	Film in the forward camera separated and camera failed on mission 1048-2			
12-Dec-68	KH-4A	Degraded film			

CORONA IMAGERY IMPROVEMENT

CORONA FIRST SPACE IMAGE
AUG 1960



CORONA IMAGE OF PENTAGON
SEPT 1967

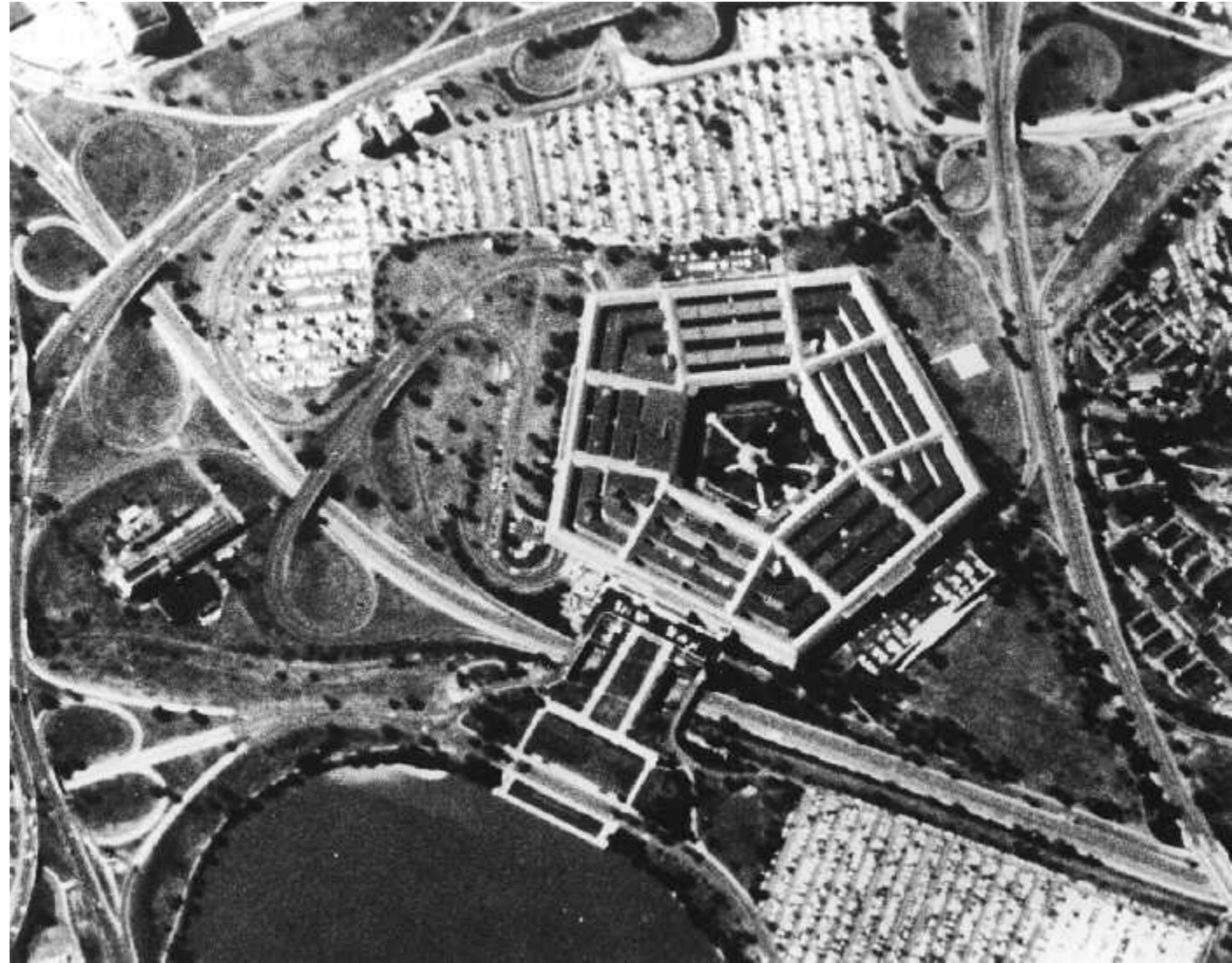

CORONA PROGRAM ACCOMPLISHMENTS

CORONA was the pathfinder for other successful space IMINT programs. It restored photoreconnaissance Intelligence collection shortly after the U-2 was shot down and established systems that were invulnerable to defense and penetrated deeper into denied areas.

The improvement in image quality over the short course of this program illustrates the rapid advancements that were made. Over the duration of the program image resolution improved from 24 to 6 foot.

The developed techniques for satellite design and operation concepts served as the foundation for the programs that followed over the next decade.